



FSM-510G Series Ethernet Management Switch Quick Start Guide

Overview

The Management Ethernet Switch solutions are designed for supporting standard industrial applications. Managed switches are easily to prioritize partition and organize user's network and provide reliable and good quality services.

The switch can be managed through RS-232 serial port via direct connection, or through Ethernet port using Telnet or Web-Based management unit, associated with SNMP agent. With the SNMP agent, the network administrator can logon the switch to monitor, configure and control each port activity in a friendly way. The overall network management is enhanced and the network efficiency is also improved to accommodate high bandwidth applications. The switch features comprehensive and useful functions such as QoS (Quality of Service), Spanning Tree, VLAN, Port Trunking, Bandwidth Control, Port Security, SNMP/RMON.

Models	L2+ Managed Switch	
	FSM-510G-2F	FSM-510G-4F
Total GE Ports	10	10
10/100/1000 BaseT(X)	8	6
100/1000 Base SFP	2	4

Safety Instructions

When a connector is removed during installation, testing, or servicing, or when an energized fiber is broken, a risk of ocular exposure to optical energy that may be potentially hazardous occurs, depending on the laser output power.

The primary hazards of exposure to laser radiation from an optical-fiber communication system are:

Damage to the eye by accidental exposure to a beam emitted by a laser source.

Damage to the eye from viewing a connector attached to a broken fiber or an energized fiber.



Specifications

Model	FSM-510G Series
Ethernet	
Copper RJ45 Ports	10/100/1000 Mbps speed auto-negotiation MDI/MDIX Auto-crossover
SFP (pluggable) Ports	100/1000Base SFP slot
Fiber port connector	LC typically for fiber (depends on module)
Power	
Power input	Redundant Input Terminals; Reverse power protection
Input voltage range	+12-48 VDC
Maximum Power consumption	10.5W
Environmental and Compliances	
Operating temperature	-40 to +75°C
Storage temperature	-40 to +85°C
Humidity	5 to 95% RH (non-condensing)
Mechanical	
Ingress protection	IP30
Dimension (without DIN rail clip)	154mm(H) x 109mm(L) x 60mm(W)
Installation option	DIN-Rail mounting Wall mounting

Faceplate

10-Port series

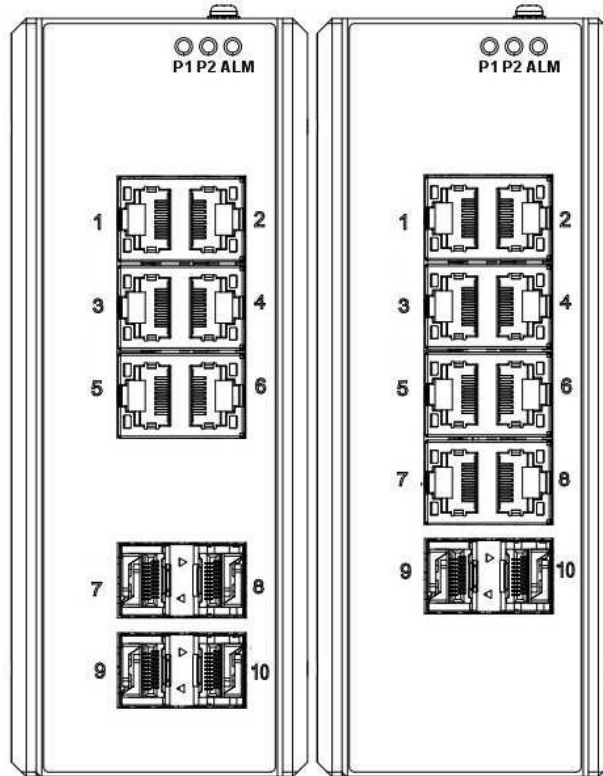

DIN-Rail Mounting

Mounting step:

1. Screw the DIN-Rail bracket on with the bracket and screws in the accessory kit.
2. Hook the unit over the DIN rail.
3. Push the bottom of the unit towards the DIN Rail until it snaps into place.

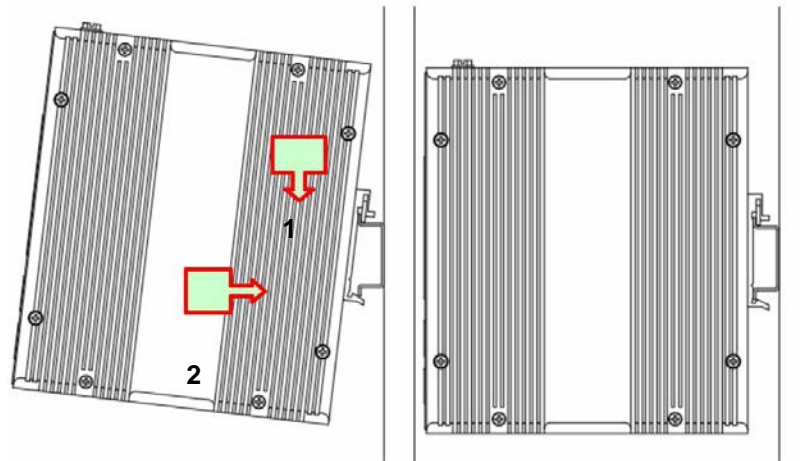

Wall Mounting

Mounting step:

1. Screw on the wall-mount plate on with the plate and screws in the accessory kit.

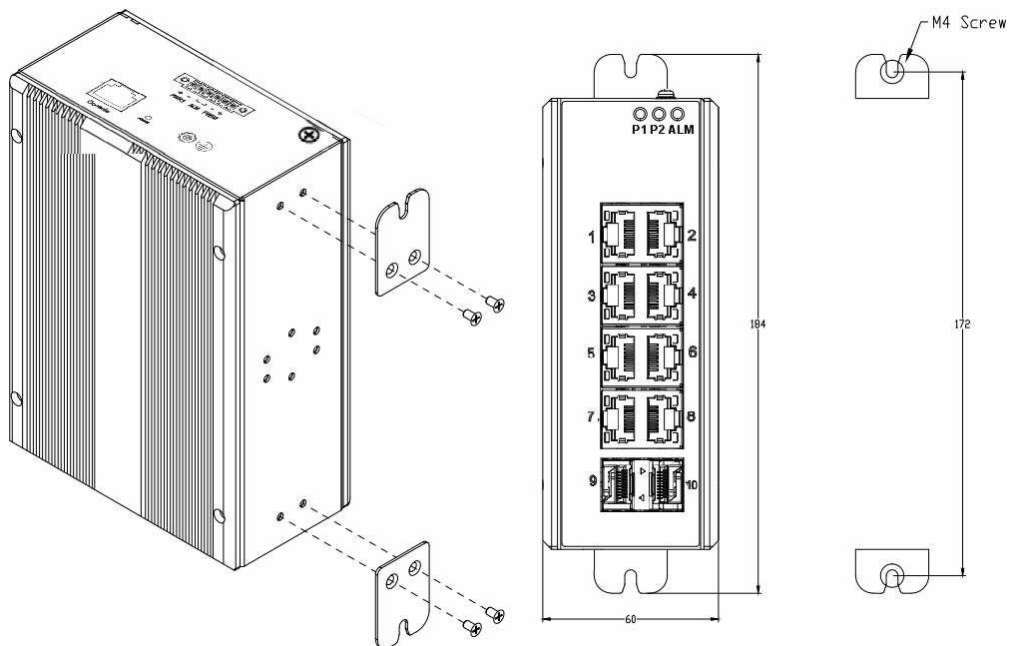

The graph is for all series

Ethernet Interface Connecting (RJ45 Ethernet)

The switches provide two types of electrical (RJ45) and optical (mini-GBIC) interfaces.

Connecting the Ethernet interface via RJ45:

To connect to a PC, use a straight-through or a cross-over Ethernet cable,

To connect the FSM-510G switch to an Ethernet device, use UTP (Unshielded TwistedPair) or STP (Shielded Twisted Pair) Ethernet cables.

The pin assignment of RJ-45 connector is shown in the following figure and table.

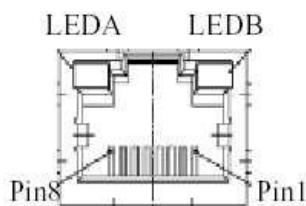

Pin	Assignment
1,2	T/Rx+,T/Rx-
3,6	T/Rx+,T/Rx-
4,5	T/Rx+,T/Rx-
7,8	T/Rx+,T/Rx-

Ethernet Interface Connecting (Fiber, SFP)

For a 100 Mbps fiber port available, please prepare the LC connectors or SC connectors (with the use of an optional SC-to-LC adapter).

For a 1000 Mbps fiber port available, please use the mini-GBIC SFP. These accept plug in fiber transceivers that typically have an LC style connector.

They are available with multimode, single mode, long-haul or special-application transceivers.

DANGER: Never attempt to view optical connectors that might be emitting laser energy.

Do not power up the laser product without connecting the laser to the optical fiber and putting the cover in position, as laser outputs will emit infrared laser light at this point.

Power Connecting

The switch can be powered from two power supply (input range 12V – 58V). Insert the positive and negative wires into V+ and V- contact on the terminal block and tighten the wire-clamp screws to prevent the wires from being loosened.

Note: 1. The DC power should be connected to a well-fused power supply.

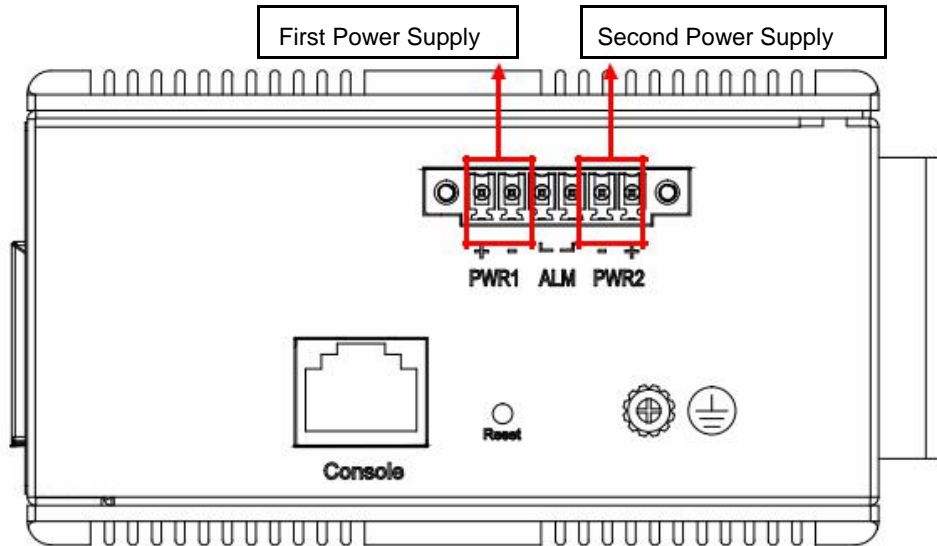

Alarm Relay and Ground Connecting

The alarm relay output contacts are in the middle of the DC terminal block connector as shown in the figure below.

By inserting the wires and set the DIP switch of the respective Port Alarm to “ON”, the relay output alarm will detect any port failures, and form a short circuit.

The alarm relay out is “Normal Open”.

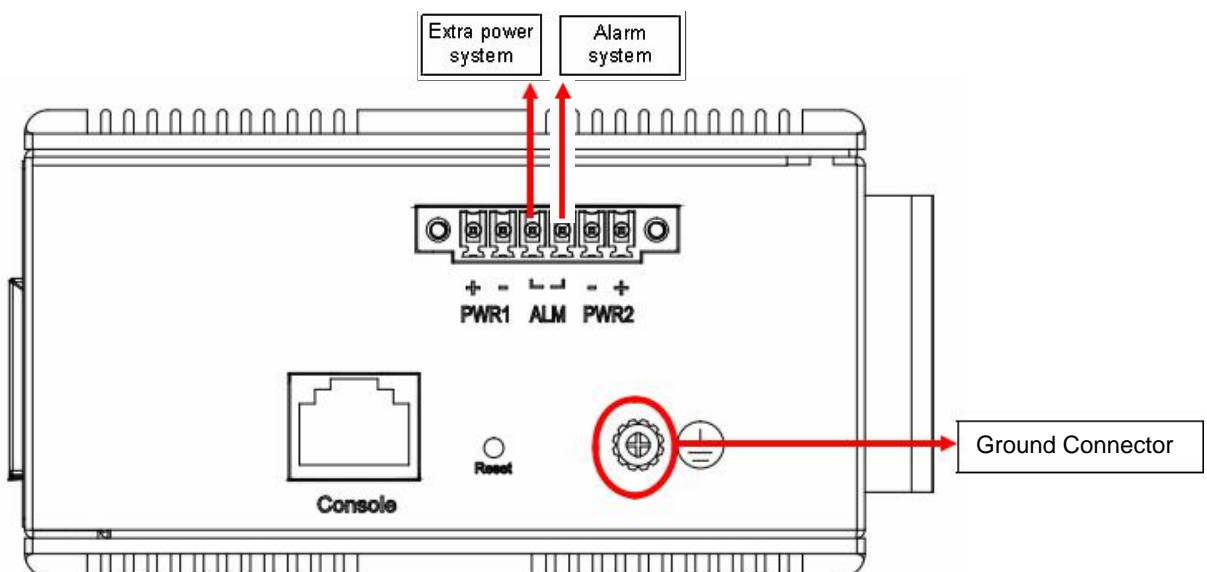

Console Connection

The Console port is for local management by using a terminal emulator or a computer with terminal emulation software.

DB9 connector connect to computer COM

port Baud rate: 115200bps

8 data bits, 1 stop

bit None Priority

None flow control

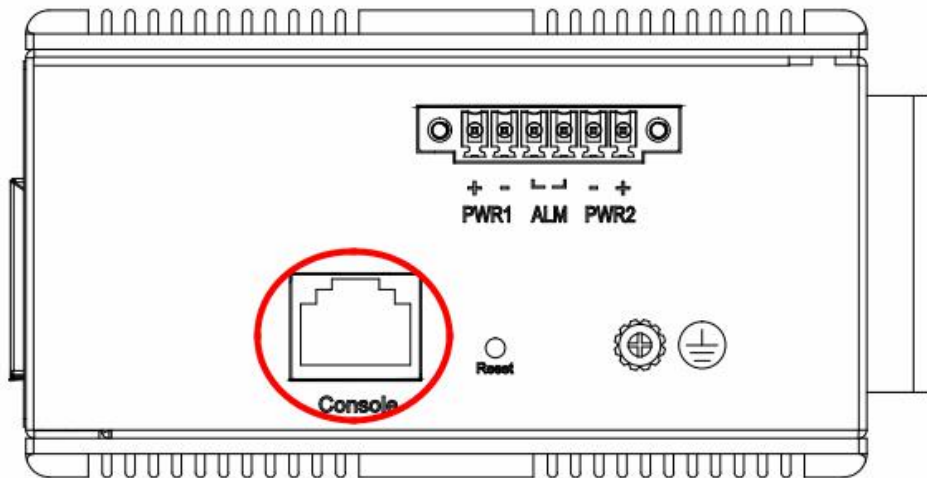

To connect the host PC to the console port, a RJ45 (male) connector-to-RS232 DB9 (female) connector cable is required. The RJ45 connector of the cable is connected to the CID port of IVS-500; the DB9 connector of the cable is connected to the PC COM port. The pin assignment of the console cable is shown below:

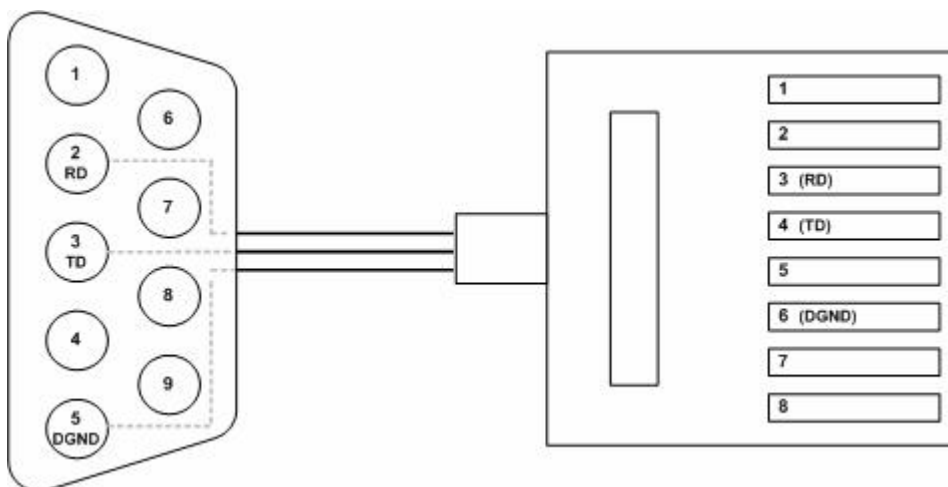



Connect & Login to FSM-510G

1. Connecting to FSM-510G Ethernet port (RJ45 Ethernet port).
2. **Factory default IP: 192.0.2.1**
3. Login with default account and password.
Username: admin
Password: (none)

CLI Initialization & Configuration (Optional)

1. Connecting to FSM-510G Ethernet port(RJ45 Ethernet port)
2. Key-in the command under Telnet: **telnet 192.0.2.1**
3. Login with default account and password.
Username: admin
Password: (none)
4. Change the IP with commands listed below: CLI Command:

```
enable
configure terminal
interface vlan 1
ip address xxx.xxx.xxx.xxx xxx.xxx.xxx.xxx
exit
```

LED STATUS INDICATIONS

LED Name	Indicator /color	Condition
P1/P2	On Green	P1/P2 power line has power
	Off	P1/P2 power line disconnect or does not have supply power
Alarm	On Red	Ethernet link fail alarm or power failure alarm occurs
	Off	No Ethernet link fail and no power failure alarm
Copper port Link/Act	On Green	Ethernet link up but no traffic is detected
	Flashing Green	Ethernet link up and there is traffic detected
	Off	Ethernet link down
Copper port Speed	On Yellow	A 1000Mbps connection is detected
	Off	No link, a 10Mbps or 100 Mbps connection is detected
SFP port Link/Act	On Green	Ethernet link up
	Off	Ethernet link down
SFP port Speed	On Yellow	SFP port speed 1000Mbps connection is detected.
	Off	No link or a SFP port speed 100Mbps connection is detected