

I-7000 Series Modules Applied in Wastewater Treatment

Zhao Juan

Shanghai Lehua Electronic Science & Technology Development Company

[I-7000 series modules](#) were used in monitoring and for data acquisition for a water treatment plant. With the dual watchdogs of [I-7000](#) series modules, the system can operate more easily and reliably.

System Introduction:

The system described consists of 6 areas: an old turbid water pump area, a new turbid water pump area, clean water pump area 1, clean water pump area 2, new thermodynamical station and old thermodynamical station. The system requires many digital input and output signals, as well as analog input signals and temperature signals. In total seventy-seven [I-7000](#) series modules were used in this system. There are 503 actual acquisition points and the field wiring reaches up to 800 meters. The system has the following features: real-time alert, history trend curve, reports and more.

[I-7000](#) series modules used in this project:

[I-7520](#) RS-232 to 485 converter

- *Speed: 300 bps—115,200 bps
- *RS-485 network with 256 modules(without repeater)
- *Voltage Isolation: 3000V
- *Supports multiple baud rates and data formats
- *Communication distance: 1.2 Km

[I-7510](#) RS-485 Repeater

- *Supports multiple baud rates: 300—115,200 bps
- *Supports multiple data formats
- * “self-tuner”inside

[I-7052](#) Isolated Digital Input Module

- *Input: 6 differential, 2 single-ended
- *Input high level (1): 3.5V~30V
- *Input low level (0): 0V~0V
- *Isolated voltage: 5000V

[I-7067](#) Relay Output Module

- *7 channels for digital output, type A
- *Relay action time: 5ms

[I-7017](#) 8-channel Analog Input Module

- *channels: 6 differential, 2 single-ended or 8 differential
- *sampling rate: 10Hz

[I-7033](#) 3-channel RTD Input Module

System Illustration

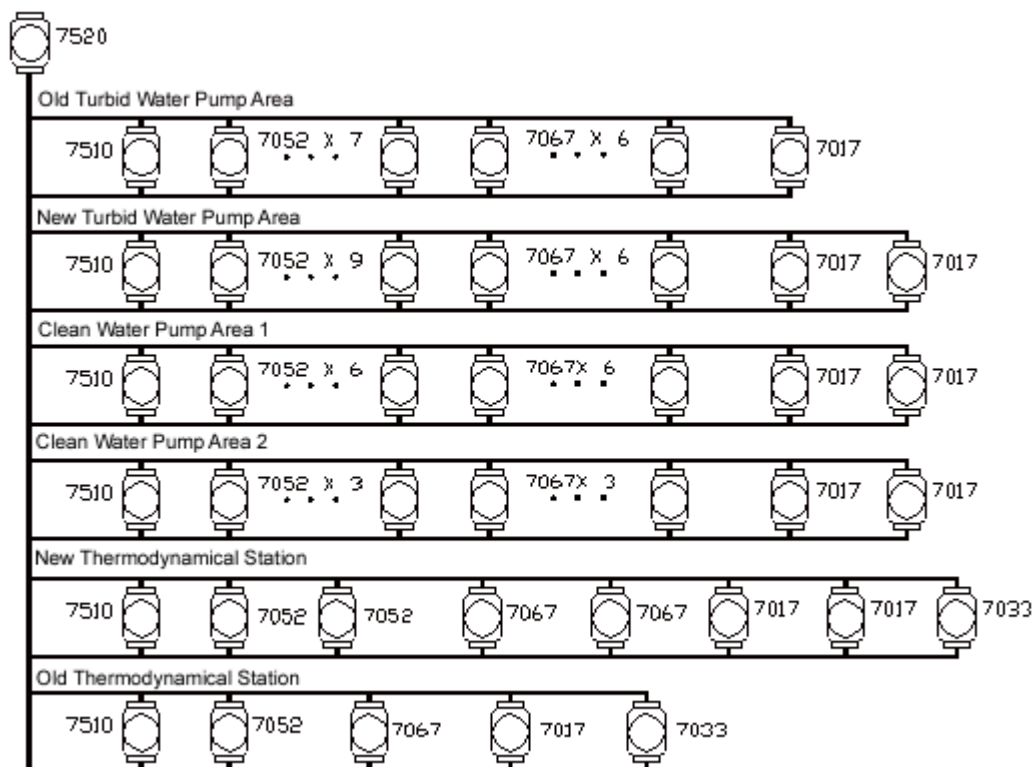

1 . Old Turbid Water Pump Area

There are five water pumps used for importing muddy water into the plant in this area. All five pumps are active during peak water consumption and only one to three pumps are active during the off-peak period. Each pump is assigned 8 digital input signals by which the on/off status and all main valves of each pump can be monitored. Additionally, each pump is assigned seven digital output signals that are used to control the status of pumps and valves in this area. The two functions can be implemented separately by seven [I-7052](#) modules and five [I-7067](#) modules. The voltage and current data for each pump can be acquired by the [I-7017](#) analog input module. All the modules in this area are placed in a switch cabinet. Communication between the front-end PC and the station is via RS-232 to 485 converter ([I-7520](#) module). Because of the long distance between the stations, a relay module [I-7510](#) is installed in the middle of the communication line.

2 . New Turbid Water Pump Area

There are 6 pumps in this area, which have the save functionality as the 5 pumps in the old turbid pump area except they are newer. Even during the off-season of water consumption the six pumps are all active. The new and old areas are 400 meters apart from each other. A total of 21 modules of [I-7052](#), [I-7067](#), [I-7017](#) and [I-7510](#) are used in this area for acquiring and controlling the data of the pumps and valves.

3 . Clean Water Pump Area

The clean water pump consists of clean water pump area 1 which contains 6 clean water pumps and clean water pump area 2 which contains 3 clean water pumps. All of the pumps are mainly used to export usable water after being processed. These cleaning water pumps are less than 200 meters apart and placed in the same computer room. However they are divided into two areas because the modules of the pumps are placed in different control cabinets with certain distances from each other. The clean water pump area 1 is equipped with 15 modules of types [I-7052](#), [I-7067](#), [I-7017](#) and [I-7510](#). The clean water pump area 2 is equipped with 9 modules of types [I-7052](#), [I-7067](#), [I-7017](#) and [I-7510](#). With these modules the system can monitor and control the status of each clean water pump.

4 . New and Old Thermodynamical Station

The two stations provide steam and power for the water plant. They also use 12 modules which fall into four types: [I-7052](#), [I-7067](#), [I-7017](#) and [I-7510](#) to acquire and control digital and analog signals. It is different from the above four station areas in that there are two [I-7033](#) modules used in the two stations to acquire the temperature of the pipe in the thermodynamical station.

5 . Issues During Debugging

(1) Because it is far away from the field facilities, sometimes certain modules in the new turbid water pump area can't be detected. After analyzing the reasons and experimenting many times this problem was resolved by adding terminal resistors to both sides of the [I-7520](#) and [I-7510](#) modules.

(2) During the use of the [I-7017](#), after the field signals were connected, address 0 appeared and couldn't be reset on-line. The reasons for this was the analog ground and power ground share the same ground level. Since the default setting of the [I-7017](#) makes INIT and Vin7- use the same port, the failure can be avoided by opening the module and changing the default setting of the 6-channel differential and 2-channel single-ended into 8-channel differential.

6. Upper Level Computer Softwar

In order to take full advantage of the [I-7000](#) series modules, KingView software is used in the upper level PC. Because this software includes drivers for all products from ICPDAS, the developer's workload is thus greatly reduced; it also takes full advantage of KingView

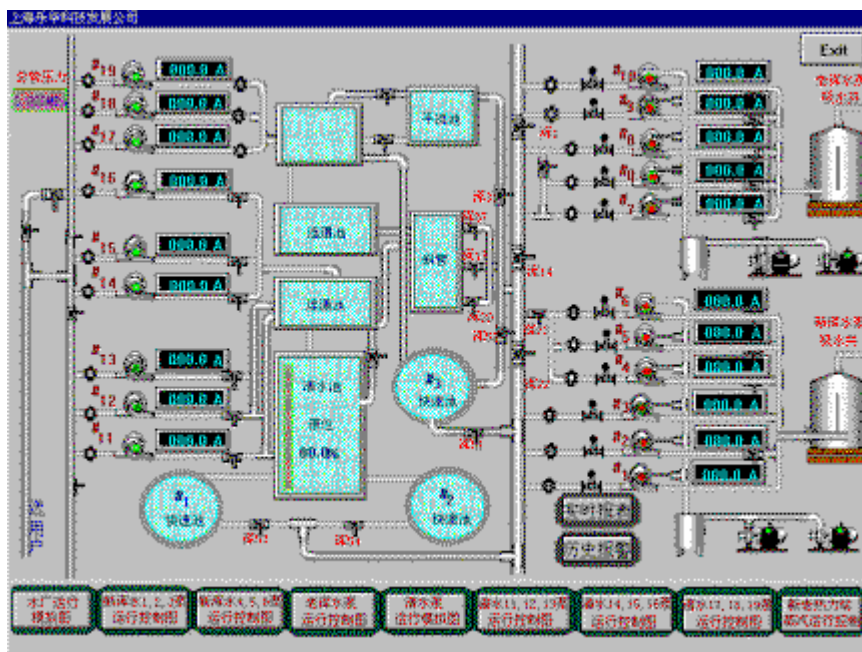

Software Operating Diagram

Software, which makes the user interface more beautiful.

Conclusion:

The project was designed by the Shanghai Wujing Chemical Plant and has been operating securely and successfully for months. This has been the first time that the plant has adopted non-imported facilities and they are satisfied with the system.