



Long Chen Paper CO., LTD. / Proctor & Gamble Taiwan

Since 1978, Long Chen Paper Company has been a successful mainstay in Taiwan's Changhua County industrial community. Both trading and manufacturing such goods as: paper, paper manufacturing machinery, industrial paper products, cogeneration equipment, and water treatment machinery, Long Chen is a multi-national subsidiary of Proctor & Gamble; who distributes Long Chen products all over the world.

Initially, Long Chen Paper Co. contacted ICP DAS with an inquiry regarding the possible integration and optimization of a more robust and holistic embedded control solution, for their primary waste water treatment / hydro-electric facility. Although already functional, Long Chen's current embedded control and data acquisition system was not providing adequate or accurate reiterations of pertinent information. Long Chen's main request was for ICP DAS to design and implement a robust and precise HMI interfaceable embedded control and data acquisition solution. The project required the use of a simple touch screen based GUI for use as an on-site point of interactivity, while at the same time allowing remote administrative monitoring and maintenance.

After a careful initial assessment, ICP DAS took a chance, and recommended that Long Chen Paper abandon their current PC based embedded control solution in favor of a more powerful and streamlined solution; a PAC (Programmable Automation Controller). By utilizing ICP's WinCON, Windows CE.net based PAC; Long Chen would have fully integrated PC based control over a multitude of expandable I/O, while benefiting from the powerful data acquisition capabilities of integral I/O modules. Further, the scope of DAQ possible from the WinCON would be virtually limitless; as ICP suggested integrating an independent USB based hard drive.

The specific model of PAC recommended by ICP was the W-8739-G. Boasting a robust 206MHz Intel Strong ARM CPU, full HMI hardware integratability (monitor, mouse, and keyboard ports), multiple means of connectivity (RS-232/485, 10 Base-T Ethernet, and USB 1.0), and a fully functional version of Windows CE.net, the controller was more than capable of handling both the control and data acquisition needs of the facility. Due to the extremely large scale of the facility, and the innumerable amount of remote locations needing to be monitored, ICP DAS further implemented seven, four channel multi-serial I/O modules, offering a total of 28 channels of RS-422/485 data to be monitored, controlled, and recorded from a single unit. The I-8144 allowed the W-8739-G WinCON PACs, self tuning, high speed data communicability, with little to no end user maintenance.

After the integration of the new hardware, Long Chen Paper Co. was more than enthused with the end results. With the controllers in place, Long Chen Paper was able to both process and control data acquired from its enormous facility; not only with better precision and efficiency, but also greater ease, thanks to the extensive HMI package designed by ICP DAS. In all, it was unanimously agreed that ICP's implementation of the PAC controller greatly superseded its predecessor (PC/PLC combination) in every regard.



- Former Structure of Long Chen Paper Co. Embedded Control Solution

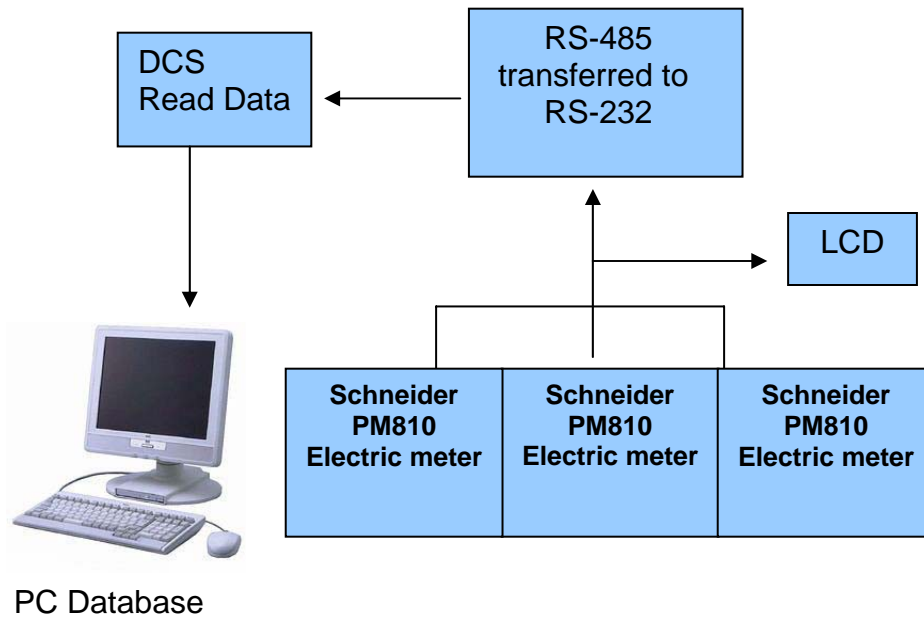

- Revised Structure of Long Chen Paper Co. Embedded Control Solution By ICP DAS

